

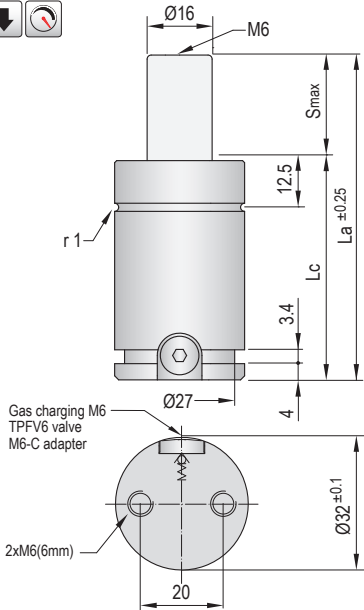

VDI SAFETY



i Pressure medium	Nitrogen (N ₂)
Max. charging pressure	125 Bar
Min. charging pressure	25 Bar
Rod seal area	2,01 cm ²
Max. temperature	120°C **
Force increase by temperature	0,33 %/°C
Maintenance kit	Kit HT300
Life service	250.000 + 500.000 strokes



FOR HIGH Temperature



How to order

TPHT 300	x	75	-	120°C
Model		Stroke		Max. operating temperature
				100°C 120°C

Code	S _{max} mm	L _a mm	L _c mm	V l	Kg
TPHT 300x10	10	50	40	0,007	0,16
TPHT 300x13	13	56	43	0,008	0,17
TPHT 300x16	16	62	46	0,010	0,18
TPHT 300x19	19	68	49	0,012	0,19
TPHT 300x25	25	80	55	0,016	0,20
TPHT 300x32	32	94	62	0,020	0,22
TPHT 300x38	38	106	68	0,024	0,24
TPHT 300x50	50	130	80	0,031	0,28
TPHT 300x63	63	156	93	0,039	0,33
TPHT 300x75	75	180	105	0,046	0,36
TPHT 300x80	80	190	110	0,049	0,38
TPHT 300x100	100	230	130	0,061	0,44
TPHT 300x125	125	280	155	0,076	0,51

Operating ** temperature	Max. charging Pressure	Initial force F _a (daN)	90% End force F _c (daN)	Max. stem speed	Max. strokes/min
80°C - 100°C	125Bar (20°C)	250 (20°C)	315 (100°C)	1m/s	10+20spm
100°C - 120°C	115Bar (20°C)	230 (20°C)	305 (120°C)	0,6m/s	5+10spm

Assembly possibilities



Follow guidelines
Page 287



DROP-IN



SCREWS

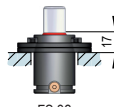

FS 32
FS 32/1-FSC 32

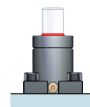

FP 32-FPR 32

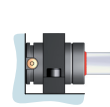

FI 32-FI 32/1